

John W. S. D. Beckler

Theory and Operation of the **ULTRA-LINEAR** Circuit

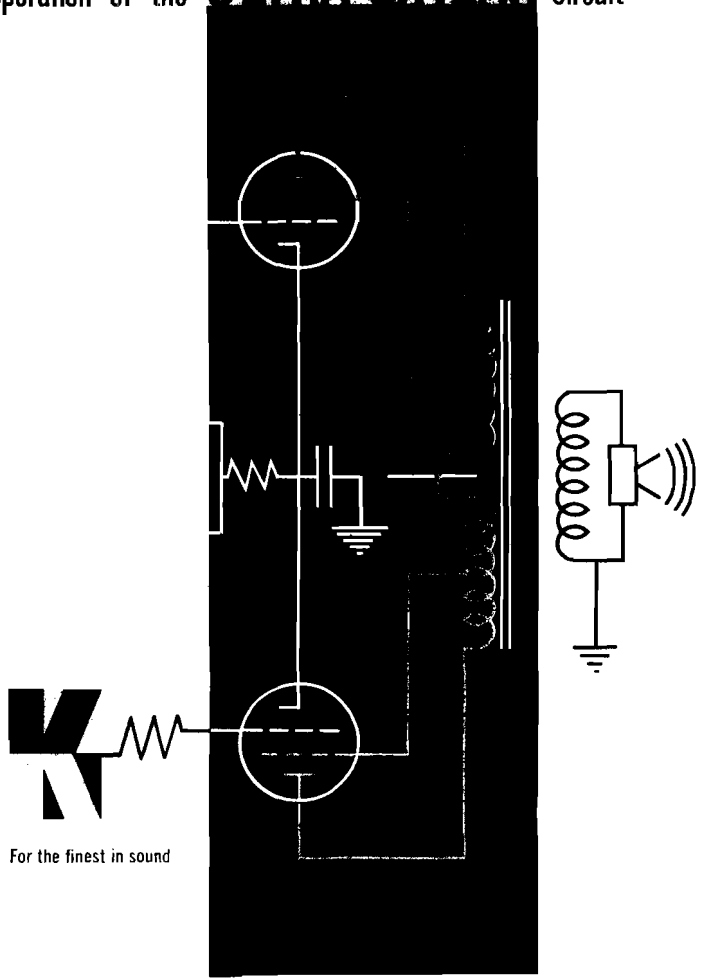

For the finest in sound

PRICE 25 CENTS

This booklet is intended to acquaint the reader with the theory and operation of the Ultra-Linear circuit, which has become recognized as one of the most suitable forms of output stage in a quality audio amplifier.

The various attributes of an amplifier with regard to the reproduction of sound of most natural quality are discussed and reduced to a technical basis. It is hoped that this will assist the lay reader in a better understanding of the jargon of technical terms which are now loosely used and little understood by even some of the popular writers.

The information offered here will give the reader a positive picture of Ultra-Linear operation and assist him in choosing an amplifier containing the genuine Ultra-Linear circuit.

THEORY AND OPERATION OF THE ULTRA-LINEAR AMPLIFIER

INTRODUCTION

Since the beginning of broadcasting, the audio amplifier has been in a continuous state of development. Quality of reproduced sound is determined to a large extent by the performance of the amplifier, and the development of amplifiers has mainly been associated with reducing distortion to an absolute minimum. Amplifier distortion is of several varieties, and the chief offender has always been waveform distortion in which the amplifier contributes a certain amount of output which is not present in the input signal. Distortion is the addition of features not in the original or the absence of features present in the original.

It has long been recognized that distortion is generated in an amplifier by a non-linear input-output characteristic curve. This curve is called the transfer curve of the amplifier, and it relates instantaneous values of output to input voltage.

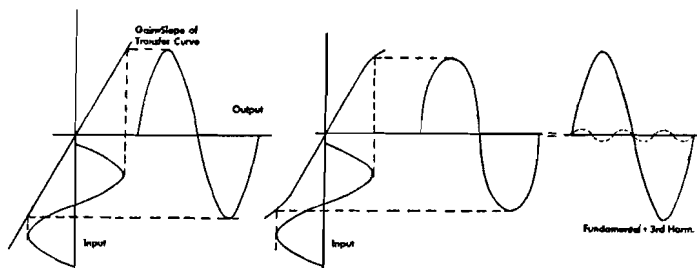

FIG. 1a

FIG. 1b

The transfer curve ideally is a straight line as shown in Fig. 1a where it is seen that an input voltage represented by a sine wave will produce an output voltage which is an exact magnified replica. The effect of a bend or curvature in the transfer curve is shown in Fig. 1b. It is seen that the shape of the output voltage has changed, and the output wave now consists of the sum of two voltages.

One of these is again a magnified replica of the input voltage, but the second is a distortion voltage of three times the frequency of the input voltage.

HARMONIC AND INTERMODULATION DISTORTION

Non-linearity of the transfer characteristic is responsible for the production of two types of distortion in an amplifier . . . harmonic distortion and intermodulation distortion. Both of these are the presence of spurious tones in the output which are not present in the input. In the first case these tones are related to the input signal in integral multiples of frequency such as 2, 3, 4, 5, etc., and in the second instance the unwanted tones contain frequencies which are the sum and difference of those in the input circuit where more than one input frequency is present.

For example if the input signal is a 1000 cycle per second tone, the output may contain frequencies of 2000, 3000, 4000, 5000 etc. cycles. These are the second, third, fourth and fifth harmonics of the original 1000 cycle tone.

Similarly the input signal may be made up of 1000 and 100 cycle tones. There can be present output frequencies of 900 and 1100 cycles. These are referred to as first order intermodulation products. There are other possible combinations of frequency which may be present such as 800 and 1200 CPS, 1900 and 2100

CPS or 1800 and 2200 CPS. These are second order intermodulation products, and are composed of sums and differences of the second harmonics of frequencies in the input signal. There may be present intermodulation distortion of even higher order. It is quite easy to see that with the complex frequency spectrum present in music a large number of spurious tones can be generated by an imperfect amplifier which will mask the entire performance.

Harmonic and intermodulation distortion are related, since each is caused by a non-linear transfer characteristic. In most amplifiers, the amount of distortion is greatest for the lower order harmonics and intermodulation products, and diminishes with higher order.

Harmonic and intermodulation distortion are measured as a percentage of the total output voltage. In rating an amplifier, the amount of distortion may be given in terms of each harmonic, or alternately may be total harmonic distortion. The total harmonic distortion is computed according to the formula

$$H_T = \sqrt{H_2^2 + H_3^2 + H_4^2 + \dots}$$

where H is the amplitude of each harmonic component.

While many measurements have been made to subjectively evaluate the effects of intermodulation and harmonics in amplifier performance, there unfortunately are no standard ratings for amplifiers of highest fidelity. An amount of intermodulation distortion of 8% is acceptable for commercial equipment, however, intermodulation as low as 1% can be detected by a discerning ear. It is, therefore, desirable to limit distortion to the smallest degree in the power amplifier, and this may be accomplished only by linearizing the transfer characteristic of the amplifier.

PHASE AND ENVELOPE DISTORTION*

There are other forms of distortion which occur in an amplifier, and it is worth mentioning these since they have an important but less severe effect on fidelity. These are phase and envelope distortion. Just as harmonic and intermodulation distortion are related to the transfer characteristic, phase and envelope distortion are also related and are due to phase shift at low and high frequencies within the amplifier. Phase distortion describes the change in appearance of a complex wave on passing through an amplifier.

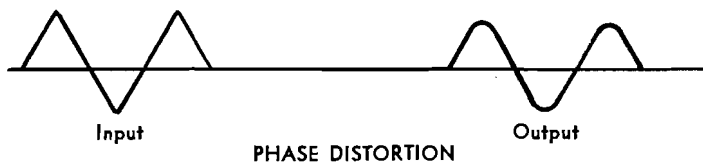

FIG. 2a



FIG. 2b

A typical example is shown in Fig. 2a which shows the change in shape of a triangular wave in going through an amplifier with considerable high frequency phase shift. It will be noted that the sharp curves are rounded due to the loss of higher fre-

*Phase distortion is here defined to mean output distortion due to both amplitude discrimination and phase shift. This is in accordance with latest circuit theory which recognizes that amplitude discrimination and phase shift go hand in hand.

quency components. Similarly Fig. 2b shows the effect of the sudden application of a train of audio signal. It will be observed that the envelope enclosing the signal has changed its rectangular shape. The first effect, phase distortion, is due to high frequency phase shift, and the second, envelope distortion, is caused by low frequency phase shift. An amplifier which suffers to a large degree from these faults is said to have poor transient response. The word transient here is used to describe the transitory nature of sound, which is non-cyclical and ever changing in pitch, loudness and complexity of wave shape and moreover is of finite duration.

The minimizing of these distortions are mainly controlled by the output transformer operating in conjunction with the feedback system, and indeed one great step forward in the development of better amplifiers has been the design of better output transformers.

COMPARISON BETWEEN PHASE AND HARMONIC DISTORTION

The reader will note that the output wave in both Fig. 1b and Fig. 2a is not the same in appearance as the input wave. Therefore in each instance distortion has been contributed to the output wave by the amplifier.

An important distinction should be made at this point. In harmonic distortion, harmonic frequencies of sound are added to the original sound content. In phase distortion another phenomenon occurs simultaneously in the amplifier—frequency discrimination—in which certain bands of frequencies may be attenuated. Complex wave shapes as exemplified by the triangular wave are composed of many harmonically related frequencies, and the loss of higher harmonics radically changes the shape of

the wave. Phase distortion has, therefore, an opposite effect, since certain essential frequencies which should be present in the output are lost.

Harmonic distortion and intermodulation distortion alter sound quality by adding discordant tones. Phase and envelope distortion alter sound quality by removing certain essential frequencies which identify a musical instrument. For example, 440 cycle middle A has the same fundamental frequency if played by either a violin or a French horn, and both of these instruments would sound the same if we listened to only the fundamental tone. Subjectively, then, we can judge the effect of phase and envelope distortion in sound by listening to the fidelity with which various instruments are reproduced. The percussive instruments are particularly good for use as a guide, since they combine extremes of low and high frequencies in their frequency spectrum.

INFLUENCE OF THE OUTPUT TRANSFORMER

Aside from the output tubes, the output transformer is probably the most important component in the power amplifier. The output transformer combines many separate functions. Its main purpose is to couple the power generated by the output tubes, which is of a high voltage, low current nature, to the speaker which requires low voltage and high current. In electrical terms the transformer couples the high impedance of the plate circuit to the low impedance of the speaker, and it must do this over the entire frequency range without discrimination or excessive phase shift.

High quality audio amplifiers employ output tubes in push-pull connection, in which the individual tube transfer curves are blended smoothly into one composite transfer curve. To accom-

lish this each half of the primary winding must be tightly coupled magnetically to the other. If this coupling is not tight the composite transfer curve will not be smooth, and large amounts of harmonic distortion will be generated.

In a high quality audio amplifier, inverse feedback voltage is invariably taken from the secondary side of the output transformer. To be effective the feedback voltage must oppose the input voltage; *i.e.* have its major component 180 degrees out of phase over a frequency spectrum which exceeds the limits of the audio band by about three times the normal high and low frequency limits. If one considers the audio range as extending from 20 CPS to 20,000 CPS, the bandwidth of the transformer at 70% response (or at 45 degrees phase shift) should at least extend from about 7 CPS to 60,000 CPS. If this is not the case large amounts of inverse feedback will provoke a particularly severe form of phase distortion in which the amplifier may be subject to oscillation at very high or very low frequencies. Such an amplifier is said to be marginally stable, and signals of abrupt transient characteristics, as percussive sounds, will cause instantaneous oscillation. High frequency oscillation of this type is sometimes known as ringing, and the entire condition is often referred to as transient instability.

Transformers like tubes have a finite capacity, and a transformer of insufficient capacity will introduce non-linearity into the transfer characteristic. This is caused by magnetic saturation of the transformer core, and this condition occurs at low frequencies since the magnetic flux density varies inversely with frequency. The transformer, therefore, must have sufficient core material to permit undistorted passage of the lowest frequencies. Selection of core material plays an important part in this respect . . . where high saturation flux density, linearity of the magnetization curve, and core loss are important factors.

At one time output transformers were far from perfect, and most designers regarded the performance limits of an amplifier to be set by the performance capabilities of the output transformer. This led some designers to mollify the situation by concentrating their efforts on the design of amplifiers of a transformerless type. Such amplifiers are, however, not practical at the present state of development, since they depend on tubes of excessive capacity, or on high impedance speakers.

Today, due to a better understanding of design principles, output transformers have been brought to a high degree of perfection as typified by the Acrosound line. These transformers combine broad bandwidth, 10 CPS to 100,000 CPS, with low phase shift, tight winding coupling, and a generous amount of linear core material. The winding arrangement of the coil provides excellent transmission of transients. This arrangement is unique and is protected by U. S. Patent Number 2,680,618 owned and controlled by Keroes Enterprises with Acro Products Co. as sole licensee.

CORRECTION OF NON-LINEAR DISTORTION

Curvature of the transfer characteristic and its effect in producing harmonic and intermodulation distortion are generated in an amplifier by the vacuum tubes since these are non-linear circuit elements for large excursions of input and output signals. This is a natural occurrence, for tubes have a finite capacity and do not overload abruptly, but instead reduce their rate of output gradually with increased signal input.

The reduction of non-linear distortion can be accomplished in several ways: by developing more linear tubes, by compensating for the imperfections of existing tubes, or by operating the tubes at reduced output so that the excursions of input and out-

put signals are only a small fraction of the capabilities of the tube. The latter method might be termed the brute force way, and it is uneconomical and inefficient.

It is interesting to follow the methods that have been developed to correct non-linear distortion in their historical order. The first great step in this direction was made with the development of the push-pull output stage. This is a compensating method and was first used with triode output tubes, the only type available at that time. The push-pull power stage eliminates the production of all even harmonic distortion by providing a symmetrical transfer characteristic, and it can easily be demonstrated when this is the case, there can be no even harmonics.

Vacuum tubes were later introduced; first the pentode and later the beam tetrode type which had greater output capabilities and higher efficiency than the triode. These tubes could be made more linear than the triode since the selection of certain values of load impedance resulted in low distortion figures. Unfortunately, however, the performance of these tubes is largely dependent on maintaining a fixed resistive load, and the average speaker load varies over wide values throughout its frequency range. In practice, therefore, harmonic distortion can be many times that of the triode. Moreover, the tetrode and pentode tubes exhibit a high output impedance which is not suitable for the best performance in a speaker.

A large step forward was made with the development of negative feedback. This process makes use of feeding back a certain percentage of the output of the amplifier which is applied to the input in opposite polarity to the input signal. When this is done the linearity of the transfer curve is greatly improved with a corresponding reduction in distortion. Negative feedback also lowers and improves the output impedance of the amplifier as far as performance with a speaker load is concerned. There is a

limit, however, to the amount of feedback that can be used in a given amplifier, and an excessive amount will negate its benefits by creating large amounts of phase distortion with attendant unstable amplifier performance.

With these improvements amplifier performance still remained far from perfect, with many subtle differences between performance of triode amplifiers and tetrode or pentode types. High fidelity enthusiasts were divided into two camps: those that favored the sweetness and solidity of sound provided by triode tubes, and those who preferred the cleanness and crispness of the pentode and tetrode. Actually each group favored the coloration of sound produced by the minute but audible types of distortions created by their selection of output tubes.

THE ULTRA-LINEAR AMPLIFIER

Of all the methods that have been devised to minimize distortion, the Ultra-Linear principle is the only one that attacks the problem at the source, in the non-linearity of the output tube itself.

The principles underlying Ultra-Linear operation of output tubes are quite simple and easily understood by referring to Figures 3a, 3b, and 3c.

Push-pull output circuits are shown in which a tetrode pair of output tubes are used. Pentodes as well as tetrodes can also be used in the Ultra-Linear circuit. Essential connections are made to the screen grid of the tube, however, the subsequent discussion will be on tetrodes with the understanding that pentodes may also be used.

In Figure 3a the tubes are shown triode connected, since each screen grid is shown connected to its respective plate. The plate current, plate voltage characteristic for each tube is shown in the

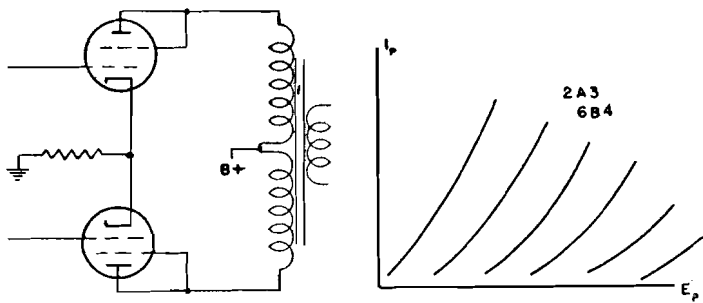

FIG. 3a

graph. Each plate current line is parabolic in shape and far from linear.

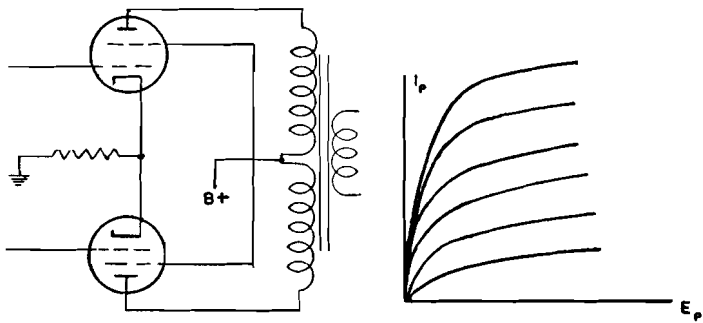

FIG. 3b

Figure 3b represents the same set of output tubes operated as tetrodes with the screen grids connected to the B plus supply voltage. A similar tetrode characteristic curve is also shown and again the tubes are not linear. However, it will be observed that each type of tube connection produces an opposite type of non-

linearity. In the first case, the curve is concave upward and in the second, concave downward. It is conceivable that an intermediate form of operation should be possible in which an average is taken between the two types of curves in which opposite curvatures cancel.

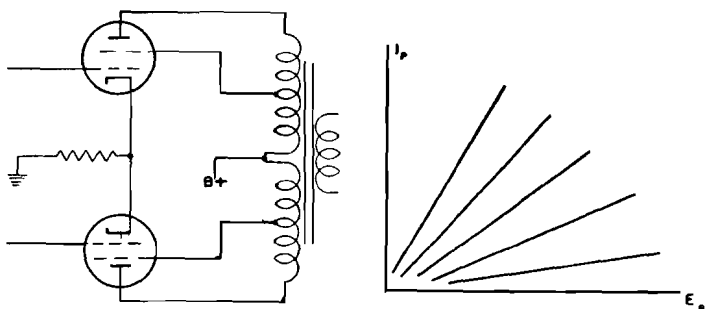

FIG. 3c

Ultra-Linear operation does this by connecting the screen grid of the tube to an intermediate tap on the output transformer according to Figure 3c. One composite plate current—plate voltage characteristic curve is illustrated, and it is seen that it is constructed as a mean between the tetrode curve and the triode curve. As the tap position is changed toward the plate end of the tube, the operating characteristics become more nearly those of a triode . . . toward the B plus connection to the transformer the curve approaches that of the tetrode.

There is a narrow range of tap position over which the characteristic curve is most linear, and tube operation through this range is called Ultra-Linear. When a tube is operated within this range, harmonic and intermodulation distortion are minimum.

Figure 4 gives a curve for push-pull KT-66 tubes which illus-

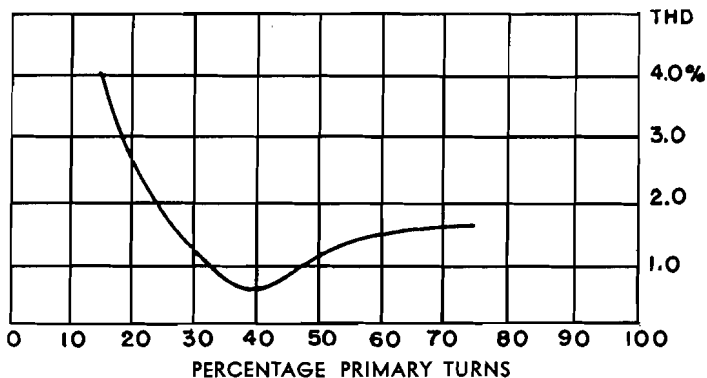

FIG 4

trates the manner in which the total harmonic distortion varies with tap location. It will be observed that the best tap occurs at approximately 40%, and the total harmonic distortion at this point is about 0.6%. It will also be observed that the maximum power that the tube can deliver is somewhat less than that afforded by pure tetrode operation, however, this is not a serious deterrent and can be compensated as will be discussed.

Table I lists recommended tap position for various tubes with comparative figures for triode, tetrode and Ultra-Linear operation. A moderate variation in tap position is permissible, but if varied over wide limits, operation approaches that of the triode or tetrode depending upon the direction in which the tap is varied.

The Ultra-Linear circuit is patented under U. S. Patent No. 2710313 owned and controlled by Keroes Enterprises. Since the date this patent was issued the circuit has found wide acceptance among amplifier manufacturers, many of whom have been granted licenses. However, to avoid payment of royalties, some manufacturers while representing their amplifiers as Ultra-Linear

TABLE 1

Tube	Operation	E_p	E_{sg}	Max. Watts	% Tot. Har. Dist.*
KT-66	Triode	400	400	15	1.6
	Tetrode	400	400	32	6
	UL 43%	400	400	32	0.6
6550	Triode	450	450	28	2.5
	Pentode	450	450	75	3.5
	UL 40%	450	450	65	1
EL-34 6CA7	Triode	400	400	16.5	3
	Pentode	475	375	58	6
	UL 40%	450	450	50	1
5881 6L6	Triode	400	400	12	1
	Tetrode	400	400	24	4
	UL 43%	400	400	24	1
6V6	Triode	285	285	4.5	2
	Tetrode	285	285	14	2
	UL 25%	285	285	10	0.8

have sidestepped the patent by operating with a screen tap outside of the recommended range with consequent performance degradation. Manufacturers who comply in every respect with the requirements of Ultra-Linear operation are permitted to display the legend "Licensed Ultra-Linear" on their product. This is your assurance that the amplifier contains the genuine Ultra-Linear circuit.



*These distortion figures are for the output stage alone without the addition of feedback. At equal power levels lower than the maximum rating the contrast between the Ultra Linear figures and those of the triode or tetrode stage is even greater.

Ultra-Linear operation does not eliminate distortion altogether. However, measurements have shown that with proper adjustments of grid bias and load, third harmonic distortion can be virtually eliminated and the percentage of higher harmonics greatly reduced. Moderate amounts of feedback can then be introduced to reduce the higher harmonics to insignificance.

MATHEMATIC ANALYSIS OF ULTRA-LINEAR OPERATION

This then forms the physical explanation of Ultra-Linear operation, and it is seen that an existing type of output tube has been transformed into a new tube more linear than its derivative. This has been accomplished by applying a portion of the output voltage from a low impedance tap on the transformer to the screen grid of the tube. This voltage is in phase with the plate voltage and a fixed fraction of it. This being the case, it has been claimed by some that Ultra-Linear operation is nothing more or less than the application of local feedback over the output stage. Ultra-Linear operation can be analyzed on a feedback basis, however, power feedback is involved in which plate circuit power is supplied to a non-linear screen grid load, and the situation is more involved than in the usual current or voltage feedback conditions between linear circuit elements.

The following analysis is based on what occurs with feedback taken to a separate electrode within a tube such as the screen or suppressor grids, and serves to illustrate that feedback of this type will introduce new curvature into an existing tube characteristic. This, of course, is contrary to ordinary ideas regarding negative feedback which have been developed on the basis that the feedback voltage and the signal voltage are

applied to a common element so that the feedback voltage and the input voltage are additive. Under the latter condition it is well known that feedback will always tend to improve linearity. However, with feedback to a separate electrode reverse curvature may be introduced to cancel existing non-linearity.

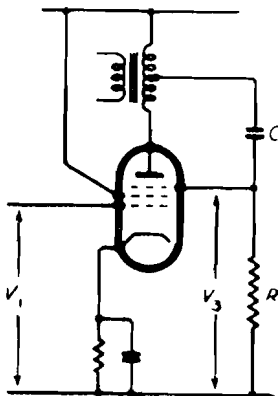

FIG. 5

A modified form of the ultra-linear amplifier is shown in Figure 5; in this, a fraction of the plate voltage is applied through the CR coupling to the suppressor grid. It is well known that in a pentode the cathode current is

$$i_k = a_1 + b_1 V_1$$

within the limits of a linear approximation. It is also well known that it is independent of V_3 which serves only to control the division of current between screen-grid and plate, so that

$$i_p = i_k (a_3 + b_3 V_3)$$

Therefore, we can write

$$i_p = (a_1 + b_1 V_1) (a_3 + b_3 V_3) \dots$$

In Fig. 5, the anode voltage is $-i_p R_a$ where R_a is the plate load.

and so V_3 equals $-\beta i_p R_a$ and (1) becomes

$$i_p = \frac{a_3(a_1 + b_1 V_1)}{1 + \beta b_3 R_a (a_1 + b_1 V_1)}$$

$$= A[a_1 + b_1(1 - a_1 B) V_1 - b_1^2 B(1 - a_1 B) V_1^2 + b_1^3 B^2(1 - a_1 B) V_1^3 \dots] \quad (2)$$

where $A = a_3 / (1 + a_1 b_3 \beta R_a)$
and $B = b_3 \beta R_a / (1 + a_1 b_3 \beta R_a)$

Feedback to the suppressor grid thus introduces curvature into an otherwise linear characteristic. If the input V_1 is a sine wave, the plate current will contain all harmonics of it.

Feedback to the screen-grid of a tube is, of course, not quite the same thing as feedback to the suppressor grid. However, as is well known, the mutual conductance does depend upon the screen voltage and so the equation for this condition must be rather like (1); there must be a term involving the product of the control and screen-grid voltages. If this product term is present, then the equation for screen-grid feedback will be of the same general form as (2).

It would thus appear that feedback to an electrode other than the input electrode is a bad thing. However, the non-linearity which it introduces is inverse to that which occurs naturally in tubes, and a critical degree of feedback to the screen improves linearity.

Let us suppose that the input grid has a non-linear action, but the feedback grid is still linear so that the equation for plate current is

$$i_p = (a_1 + b_1 V_1 + c_1 V_1^2 + d_1 V_1^3) (a_3 + b_3 V_3)$$

and as before $V_3 = -\beta i_p R_a$ Then

$$i_p = \frac{a_3(a_1 + b_1 V_1 + c_1 V_1^2 + d_1 V_1^3)}{1 + \beta b_3 R_a (a_1 + b_1 V_1 + c_1 V_1^2 + d_1 V_1^3)}$$

$$=A \frac{a_1 + b_1 V_1 + c_1 V_1^2 + d_1 V_1^3}{1 + B (b_1 V_1 + c_1 V_1^2 + d_1 V_1^3)}$$

where A and B have the same values as before. This equation can be expanded to the form

$$i_p = A [a_1 + (b_1 - a_1 B) V_1 - (1 - a_1 B) (b_1^2 B - c_1) V_1^2 + \{ B^2 b_1^3 (1 - a_1 B) - B b_1 c_1 (1 - 2a_1 B) - B (a_1 d_1 + b_1 c_1) + d_1 \} V_1^3 \dots]$$

retaining terms only up to the cube.

It is at once evident that it may be possible to choose β so that the coefficient of V_1^3 is zero. It is not worthwhile to attempt to work out the condition for this. The equation would be complex and of little practical utility because we have assumed a linear control of plate current by the feedback grid and this is unlikely to be present in practice.

With feedback to a grid other than the sign grid, we are given the possibility of adjusting the amount of feedback so that a particular harmonic can be eliminated from the output. In the usual push-pull output circuit even harmonics are ideally eliminated. Third and higher odd harmonics can be virtually eliminated by choosing the screen tap position for minimum distortion.

EXPERIMENTAL METHOD OF FINDING TAP POSITION

As indicated above the analytic procedure of finding tap position is unwieldy to use in practice, and in any event the various constant coefficients would have to be found by experimental data.

Certain tube manufacturers have published static sets of Ultra-Linear tube characteristic curves which can be used in

much the same way as the more conventional triode or tetrode characteristic curves. The composite push pull characteristic curve and the transfer curve of the output stage can then be constructed by graphical means, and from these the harmonic content computed.

However, it is easier to make measurements on the output stage alone under conditions of variable grid bias, load impedance and percentage tap in order to establish optimum operating conditions.

The interested reader will find details of a complete analysis given in reference 1.

OTHER ADVANTAGES OF ULTRA-LINEAR OPERATION

The principal advantage of Ultra-Linear is that the distortion is so very much lower that the total circuit feedback can be less, leading to a higher stability margin or in many cases making possible the use of a cheaper output transformer for the same stability margin. Another important advantage is that the linearity characteristic is practically straight up to the grid current point, giving constant amplifier gain even without feedback. Pentodes suffer from drooping linearity characteristics and only have about one-third of the full amount of feedback at high levels where it is most wanted.

When compared on the basis of power output on a constant supply voltage Ultra-Linear operation shows a drop in maximum power output. This drop occurs because, on the positive peak of the grid driving cycle, the screen voltage is reduced below that which would occur with the pentode operation, so that the maximum signal plate current is reduced. However, the efficiency may be made to be almost the same as for pentode operation, and, circumstances and tube voltage ratings permit-

ting, if the Ultra-Linear amplifier is supplied with the same power input as the pentode. By increasing the Ultra-Linear supply voltage, approximately the same power output will be given by both, and the combined plate and screen dissipation will be roughly the same.

The screen dissipation is less with Ultra-Linear operation, so that conditions of operation are sometimes permissible with Ultra-Linear which are not permissible with pentode operation. The only disadvantage of Ultra-Linear compared with pentode operation appear to be the slight loss in voltage gain, the reduced power output (unless the supply voltage is increased) and the slightly increased cost due to the tapped transformer.

As compared with triode operation Ultra-Linear operation has higher power output, greater efficiency, less total harmonic distortion and requires less driving voltage. Like triode operation the output impedance is low and high damping factors can be obtained. Also the stage is not critical with regard to a variable reactive load as represented by the average speaker.

TYPICAL QUALITY AMPLIFIER DESIGN

An example of a quality amplifier design which has enjoyed considerable popularity among high fidelity enthusiasts is the Ultra-Linear Williamson amplifier circuit. The basic circuit is due to a design by D. T. N. Williamson and named after its designer. Although there have been many variations of the original circuit the distinguishing features are to be found in the stage lineup.

The amplifier consists of four resistance coupled stages, the first a voltage amplifier which is directly coupled to the second stage, a cathodyne phase inverter. This is followed by a push pull driver stage which excites the grids of the output tubes.

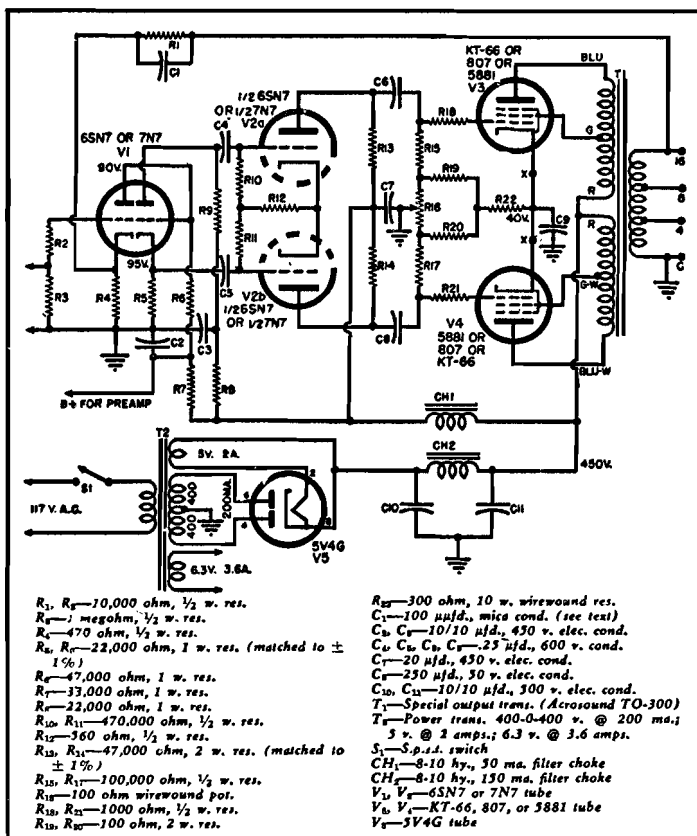

The advantage of this circuit arrangement is that it provides the output stage with an abundant amount of well balanced, low distortion drive.

The output tubes are used in Ultra-Linear connection with an Acrosound TO-300 output transformer. This transformer

carries primary taps which are tapped into the primary at 43% of the total turns of each half primary. The output transformer has an extremely wide bandwidth, + 1 DB 10 CPS to 100 KC. This makes it possible to carry 20 DB of negative feedback around the complete amplifier. It will be noted that feedback is used in the most effective way, the feedback voltage is taken from the secondary of the output transformer to the cathode of the input stage.

Any one of several similar varieties of output tubes may be used, 5881, KT-66, or 807. The maximum undistorted power output is 24 watts using the 5881 and just over 30 watts with the KT-66 and 807. At this output intermodulation distortion is about 1½%.

The frequency response of the amplifier is + 1 DB from 2 CPS to 200,000 CPS and full output power is available from 20 CPS to 20 KC. The transient characteristics of the amplifier are excellent, a 20 KC square wave is reproduced with little distortion, and it is still possible to recognize the salient features of a 50 KC square wave. Those who have used the amplifier are in general agreement that it provides the best sound at the present stage of the art.

Higher power versions of the Ultra-Linear Williamson amplifier are available and those who are interested are invited to write for details.

BIBLIOGRAPHY

1. F. Langford Smith & A. R. Cheaterman, Ultra Linear Amplifiers—Radiotronics, Volume 20, Nos. 5, 6, 7 (May, June, July 1955).
2. H. Keroes & D. Hafler—U. S. Pat. 2710313. An Ultra Linear Amplifier.
3. Ultra-Linear Amplifiers—Wireless Engineer, August 1955.